

MINIMILL

Nut- und Formzirkularfräsen

groove milling by circular interpolation

Typ ZH10

Fräseschaft Stahl

milling shank steel

D min. 10 mm

D min. 10 mm

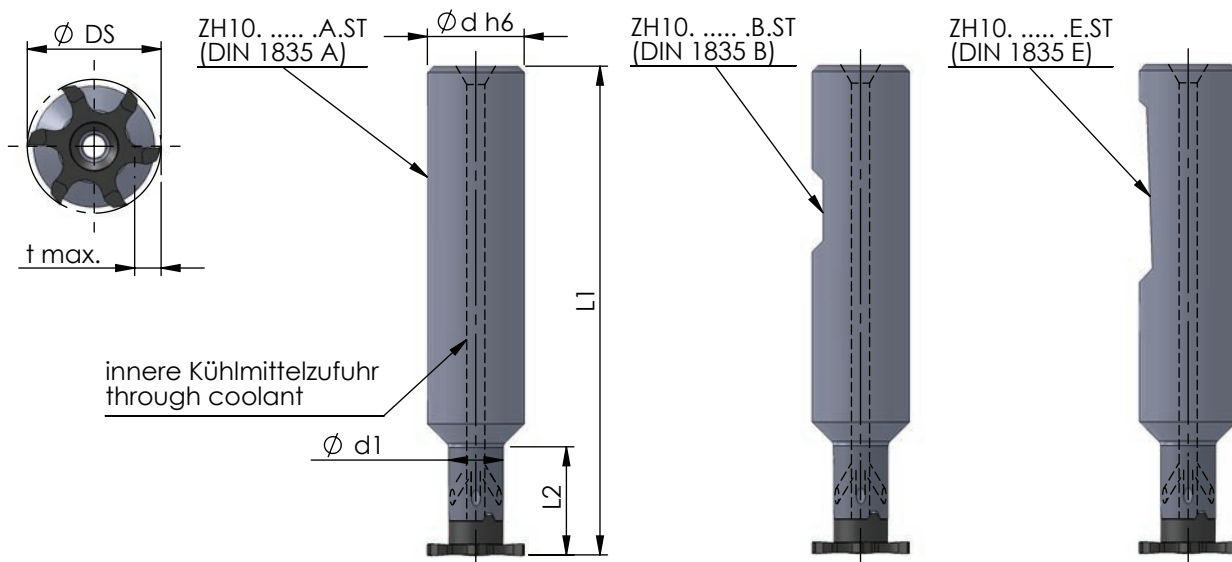

Abmessungen und Beschreibungen gelten für alle Varianten

dimensions and descriptions are valid for all versions

Abmessungen in mm

dimensions in mm

Bestellnummer part number	Ø d h6	d1	L1	L2	Typ: t max./ Schneidkreis-Ø DS	Spannschraube screw	Schraubenschlüssel wrench	Anzugs- drehmoment torque	für Schneideinsatz for insert
ZH10.1606.12.A.ST / ...B.ST / ...E.ST	16	6	80	12	Z12: 2.5 / 11.7 Z612: 2 / 11.7	Z12...	Z610...	Z612...	

Bestellbeispiel:
ZH10.1606.12.A.ST

order-example:
ZH10.1606.12.A.ST



MINIMILL

Nut- und Formzirkularfräsen

groove milling by circular interpolation

Typ ZH10

Frälerschaft Hartmetall

D min. 10 mm

milling shank carbide

D min. 10 mm

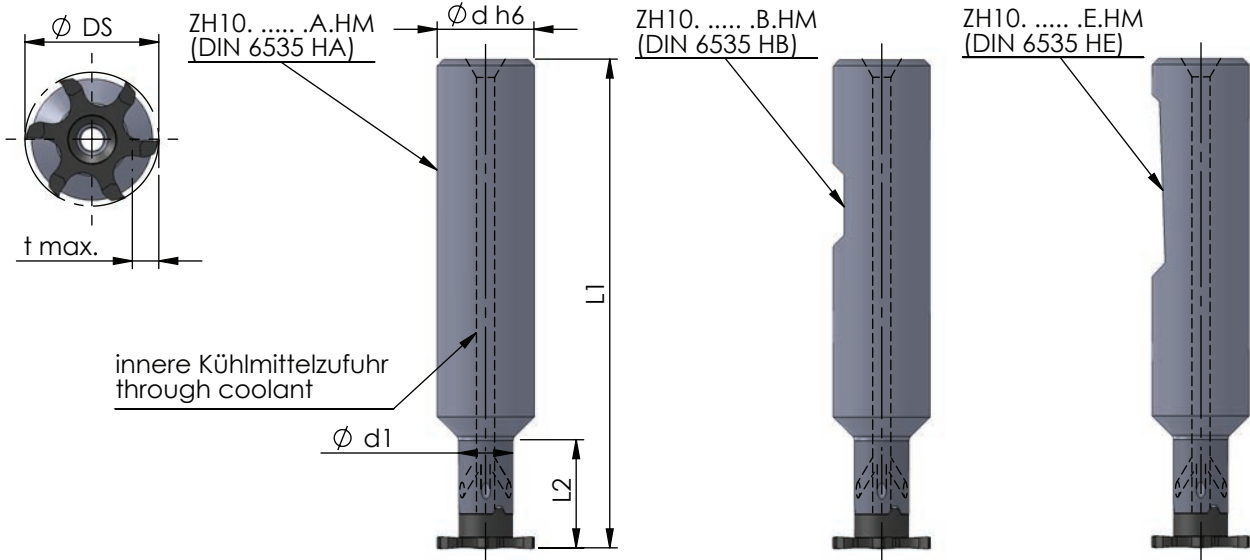

Abmessungen und Beschreibungen gelten für alle Varianten

dimensions and descriptions are valid for all versions

Abmessungen in mm

dimensions in mm

Bestellnummer part number	Ø d h6	Ø d (inch)	Ø d1	L1	L2	Typ: t max./ Schneidkreis-Ø DS	Spannschraube screw	Schraubenschlüssel wrench	Anzugs- drehmoment torque	für Schneideinsatz for insert
neu ZH10.1206.21.A.HM /...B.HM /...E.HM	12	6	80	21						
ZH10.U1206.21.A.HM /...B.HM	12.7	1/2"	6	80	21					
neu ZH10.1206.30.A.HM /...B.HM /...E.HM	12	6	90	30						
ZH10.U1206.30.A.HM /...B.HM	12.7	1/2"	6	90	30					
neu ZH10.1206.42.A.HM /...B.HM /...E.HM	12	6	100	42	Z10: 1.5 / 9.7 Z12: 2.5 / 11.7 Z612: 2 / 11.7	M2.6-MM	T 8F	2.0 Nm	Z10... Z12... Z610... Z612...	
ZH10.U1206.42.A.HM /...B.HM	12.7	1/2"	6	100	42					
neu ZH10.1207.30.A.HM /...B.HM /...E.HM	12	7.3	90	30	t max. reduziert					
ZH10.U1207.30.A.HM /...B.HM	12.7	1/2"	7.3	90	30	t max. reduziert				
ZH10.1607.25.A.HM /...B.HM /...E.HM	16	7.3	100	25	t max. reduced					

Hinweis:
Hartmetall-Frälerschäfte mit beschädigter
Schneidplattenaufnahme können durch unseren
Reparaturservice instand gesetzt werden.

note:
carbide-toolholder with damaged seating can be
repaired by Dümmel.

Bestellbeispiel:
ZH10.1607.25.A.HM

order-example:
ZH10.1607.25.A.HM