



MINIMILL

Nut- und Formzirkularfräsen

groove milling by circular interpolation

Typ Z622

für metrisches ISO-Gewinde außen Vollprofil

for metric standard threading external full profile

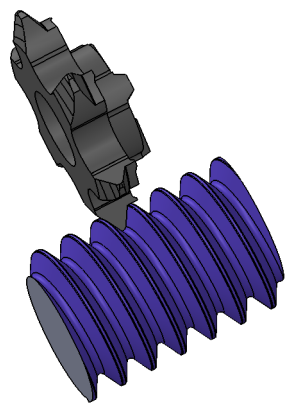
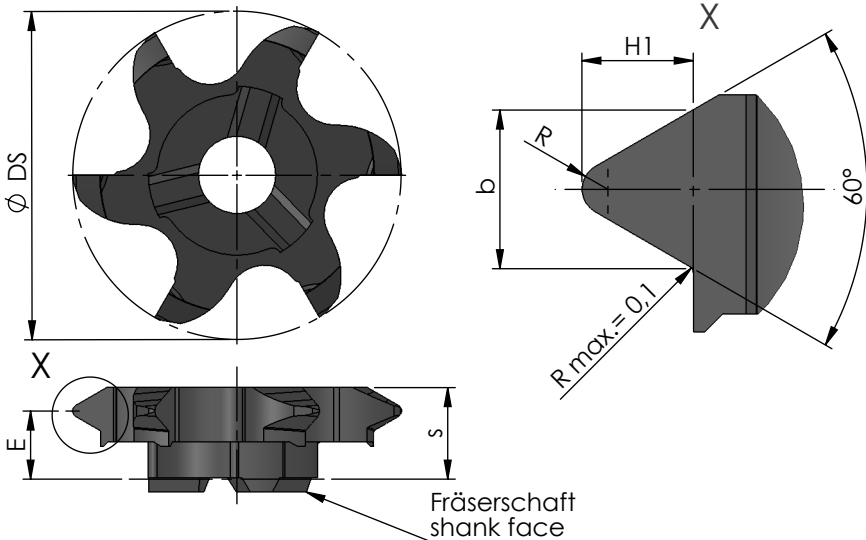

Abmessungen in mm

dimensions in mm

Bestellnummer part number	Steigung pitch	S	E	R	$\varnothing DS$	$b \pm 0.01$	H1	Zähnezahl number of teeth	K10F AL41F P18C	für Frälerschaft for toolholder type
Z622.E0815.02	1.50	6.25	5.35	0.22	21.7	1.316	0.92	6	●	ZH22
Z622.E0917.02	1.75	6.25	5.25	0.25	21.7	1.524	1.07	6	●	
Z622.E1020.02	2.00	6.25	5.10	0.29	21.7	1.755	1.23	6	●	
Z622.E1630.02	3.00	6.25	4.50	0.43	21.7	2.621	1.84	6	●	
Z622.E2140.02	4.00	6.25	4.00	0.58	21.7	3.499	2.45	6	●	

weitere HM Sorten siehe Hauptkatalog Seite 370

more carbide grades main catalogue page 370

Bestellbeispiel:
für Sorte AL41F:
Z622.E0815.02/AL41F

order-example:
grade AL41F:
Z622.E0815.02/AL41F