

Z14

Nutfräsen allgemein

for groove milling
general use

ab Bohrung Ø 14 mm

min. bore Ø from 14 mm

MINIMILL

Nut- und Formzirkularfräsen

groove milling by circular
interpolation

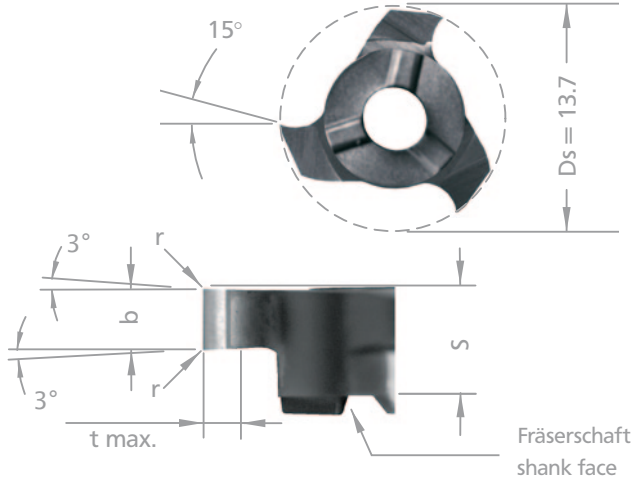

Abmessungen in mm

dimensions in mm



Bestellnummer
part number

D min.

S

r

b +0.02

t max.

Zähnezahl
number of teeth

für Frälerschaft
(S. 265)
for toolholder type
(p.265)

Standard HM Sorte
standard carbide grade

Z14.0100.00

14

4.5

-

1.0

2.5

3

Z14.0150.00

14

4.5

0.2

1.5

2.5

3

Z14.0200.00

14

4.5

0.2

2.0

2.5

3

Z14.0250.00

14

4.5

0.2

2.5

2.5

3

ZH14

AL41F (=TIALN)

HM Sorten siehe S. 370
«Sortenübersicht» und Preisliste

Bestellbeispiel:
für Sorte AL41F:
Z14.0100.00/AL41F

carbide grades p. 370 see «grades
summary» and according price list

order-example:
grade AL41F:
Z14.0100.00/AL41F