

MINIMILL

Nut- und Formzirkularfräsen

groove milling by circular interpolation

Typ Z18

Vollradius

D min. 18 mm
t max. = 3.5

full radius

D min. 18 mm
t max. = 3.5

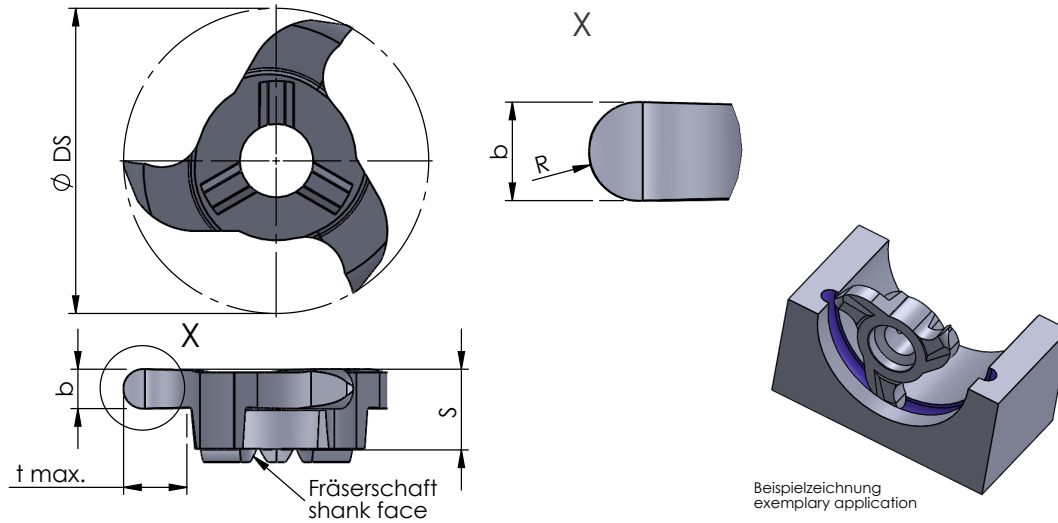

Abmessungen in mm

dimensions in mm



neu

Bestellnummer part number												für Fräseschaft for toolholder type
	D min.	S	R	Ø DS	b +0.03	b (inch)	t max.	Zähnezahl number of teeth	K10F	AL41F	P18C	
Z18.0010.20	18	5.8	1.0	17.7	2.0		3.5	3	●			ZH18
Z18.0011.22	18	5.8	1.1	17.7	2.2		3.5	3		●		
Z18.U011.23	18	5.8	1.19	17.7	2.38	0.094"	3.5	3	●	●		
Z18.0015.30	18	5.8	1.5	17.7	3.0		3.5	3		●		

Weitere HM Sorten können Sie in der Sortenübersicht im Kapitel "Technische Hinweise" und der Preisliste finden.

Bestellbeispiel:
für Sorte AL41F:
Z18.0010.20/AL41F

More carbide grades you can find in the grades summary in the chapter "technical instructions" and in the price list.

order-example:
grade AL41F:
Z18.0010.20/AL41F