



MINIMILL

Nut- und Formzirkularfräsen

groove milling by circular interpolation

Z12

Vollradius

full radius

ab Bohrung Ø 12 mm

min. bore Ø from 12 mm

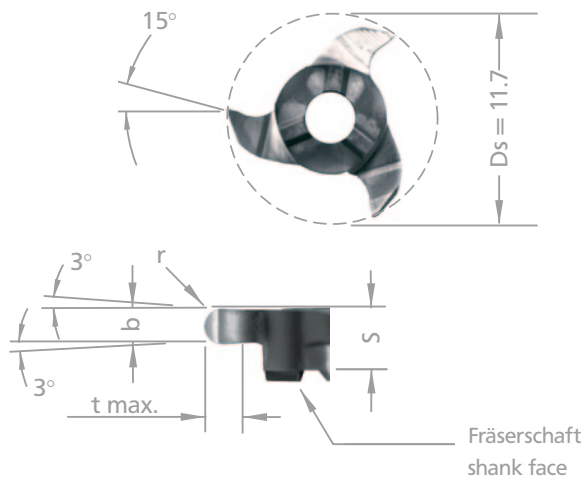

Abmessungen in mm dimensions in mm

Bestellnummer part number	D min.	S	r	b + 0.03	t max.	Zähnezahl number of teeth	für Frälerschaft (S. 262) for toolholder type (p. 262)	Standard HM Sorte standard carbide grade
Z12.0011.22	12	3.5	1.1	2.20	2.5	3	ZH10	AL41F (=TIALN)

HM Sorten siehe S. 370
«Sortenübersicht» und Preisliste

Bestellbeispiel:
für Sorte AL41F:
Z12.0011.22/AL41F

carbide grades p. 370 see «grades
summary» and according price list

order-example:
grade AL41F:
Z12.0011.22/AL41F