



MINICUT

Bohrungsbearbeitung

grooving, boring and profiling

Typ Axialstechen

am Zapfen vorbei, Vollradius

type face grooving,
in pivots, full radius

Nutaußen-Ø ab 12 mm

from outer groove Ø from 12 mm

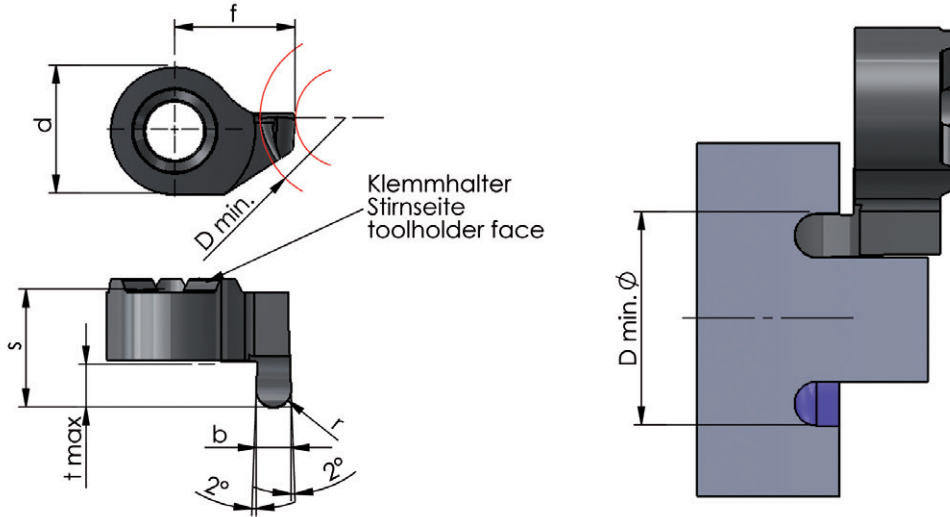

Rechts (R): wie gezeichnet
Platte linksschneidend
Links (L): spiegelbildlich
Platte rechtsschneidend
Ausführung rechts (R) oder
links (L) angeben
Abmessungen in mm

righthand (R): as shown
(rotation left)
lefthand version (L): mirror image
(rotation right)
state right (R) or left (L) version
dimensions in mm

	Bestellnummer part number	b+0.03	f	r	s	d	t max.	D min.	Klemmhalter Typ toolholder type		
									K10F	AL41F	P18C
neu	R/L S014.1210.05	1.0	8	0.5	8.3	9	1.5	12	●		
neu	R/L S014.1216.08	1.6	8	0.8	8.3	9	2.5	12	●		
neu	R/L S014.1220.10	2.0	8	1.0	8.3	9	3.0	12	●		
neu	R/L S014.1225.12	2.5	8	1.25	8.3	9	3.0	12	●		
neu	R/L S014.1230.15	3.0	8	1.5	8.3	9	3.0	12	●		
neu	R/L S014.1220.50	2.0	8	1.0	10.3	9	5.0	12	●		614 614A
neu	R/L S014.1225.50	2.5	8	1.25	10.3	9	5.0	12	●		
neu	R/L S014.1230.50	3.0	8	1.5	10.3	9	5.0	12	●		

weitere HM Sorten siehe Hauptkatalog Seite 136

more carbide grades main catalogue page 136

Bestellbeispiel:
für rechte Ausführung und Sorte
RS014.1210.05/AL41F

order-example:
righthand version and grade
RS014.1210.05/AL41F