

MINIMILL

Nut- und Formzirkularfräsen

groove milling by circular interpolation

Z610

für metrische ISO-Gewinde

for metric standard threading

innen Teilprofil
ab Bohrung \varnothing 10 mm

internal partial profile
min. bore \varnothing 10 mm

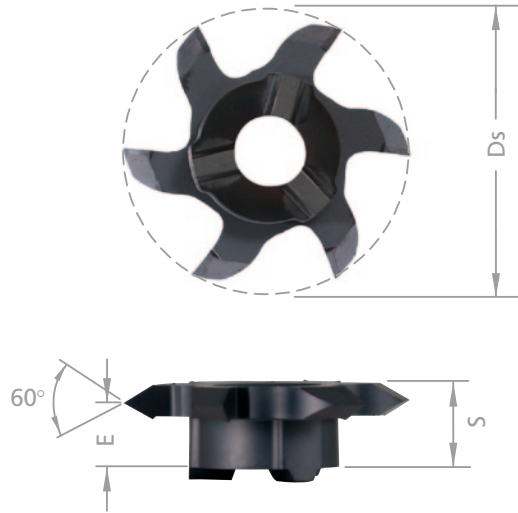

Abmessungen in mm

dimensions in mm

Bestellnummer part number	min. Gewindegröße min. thread size	Steigung P pitch P	S	E	t max.	Zähnezahl number of teeth	\varnothing DS	für Fräseschaft (S. 262) for toolholder type (p. 262)	Standard HM Sorte standard carbide grade
Z610.0510.01	M12	1.0 - 1.75	3.2	2.35	1.08	6	9.8	ZH10	AL41F (=TiAlN)
Z610.0720.01	M14	1.0 - 2.0	3.2	2.18	1.25	6	10.1	ZH10	
Z610.0815.01	M16	1.5 - 2.75	3.2	2.0	1.67	6	11.0	ZH10	
Z610.2530.01	M16	2.0 - 3.0	3.2	1.9	1.78	6	11.1	ZH10	

HM Sorten siehe S. 370
«Sortenübersicht» und Preisliste

Bestellbeispiel:
für Sorte AL41F:
Z628.1525.01/AL41F

carbide grades p. 370 see «grades
summary» and according price list

order-example:
grade AL41F:
Z628.1525.01/AL41F