

MINIMILL

Nut- und Formzirkularfräsen

groove milling by circular interpolation

Typ Z616 / Z616X

Nutfräsen allgemein

for groove milling general use

Bohrungs-Ø ab 16 mm

bore Ø from 16 mm



Z616 geradverzähnt / spur-toothed

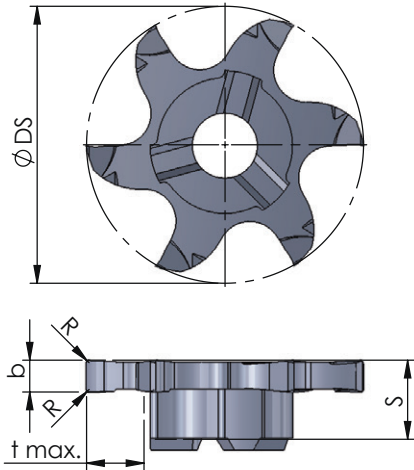

Z616X kreuzverzähnt / cross-toothed

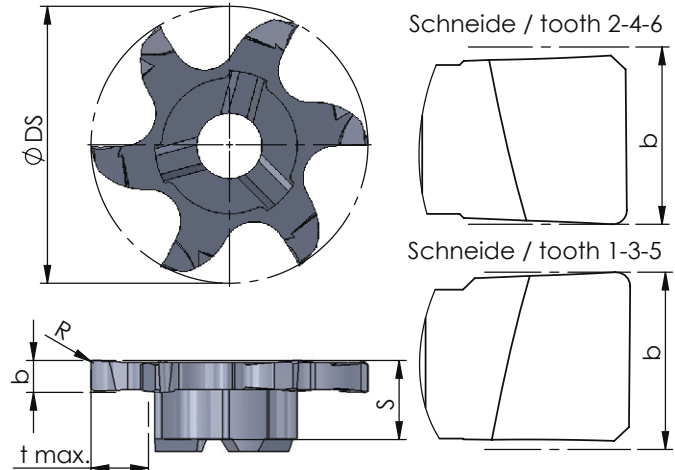

Abmessungen in mm

dimensions in mm



	Bestellnummer part number	D min.	S	R	Ø DS	b +0.02	t max.	Zähnezahl number of teeth	Material			für Fräseschaft for toolholder type
									K10F	AL41F	P18C	
neu	Z616.0150.02	16	4.5	0.2	15.7	1.5	2.5	6	●			ZH14
neu	Z616X.0150.02	16	4.5	0.2	15.7	1.5	2.5	6	●			
neu	Z616.0200.02	16	4.5	0.2	15.7	2.0	2.5	6	●			
neu	Z616X.0200.02	16	4.5	0.2	15.7	2.0	2.5	6	●			
neu	Z616.0250.02	16	4.5	0.2	15.7	2.5	2.5	6	●			
neu	Z616X.0250.02	16	4.5	0.2	15.7	2.5	2.5	6	●			

weitere HM Sorten siehe Hauptkatalog Seite 370

more carbide grades main catalogue page 370

Bestellbeispiel:
für Sorte AL41F:
Z616X.0150.02/AL41F

order-example:
grade AL41F:
Z616X.0150.02/AL41F